

Delta 901 Series

Premium Filters

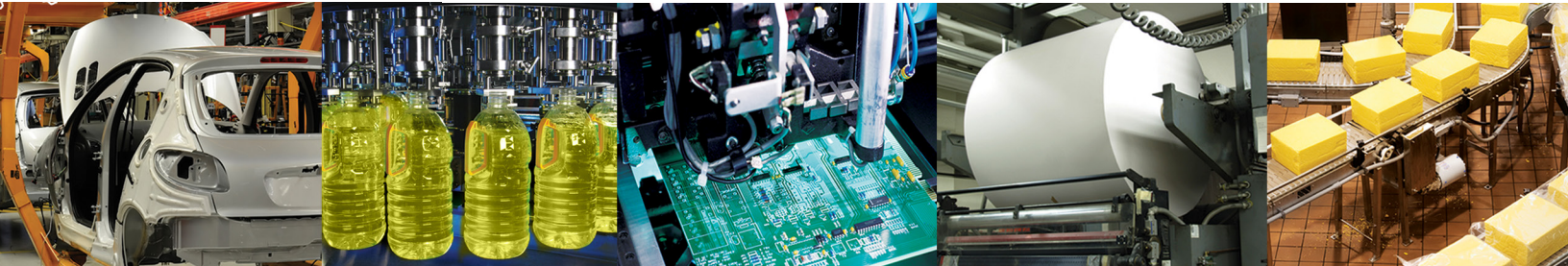

Delta 901 Series

Features and Benefits	3
Science of Coalescing Filtration	4
Water Separator	5
How to Order - Water Separators	6
Pressure and Temperature Specifications - Water Separators	6
3.0 Micron Particulate Filter	7
1.0 Micron Coarse Coalescer	8
0.01 Micron Fine Coalescer	9
0.01 Micron Ultra Fine Coalescer	10
Adsorbing Grade Filter	11
How to Order - Filters: Particulate, Coalescing, Adsorbing	12
Pressure and Temperature Specifications - Particulate, Coalescing, Adsorbing	12
Recommended Filter Combinations - Industry Applications	14
ISO Classifications Chart	14
Separator and Filter Dimensions - Std. Manual Drain / Mounting Bracket Dimensions	15
Separator and Filter Dimensions - Option "W" External Auto Drain Included	16
Replacement Parts and Kits	17

Features and Benefits

PREMIUM FILTERS



The Numatics Delta Series™ offers premium filtration for applications which require high flows. The standard aluminum end caps on every element, premium manual drain, seals made of Fluorocarbon (FKM), and available 3 micron internal pleated prefilter sets the Delta Series™ apart from our competition. The Delta series premium filters are CRN registered (CRN# 0H12256.5C - Port sizes 1/4 to 2).

Delta Series™ filters are ideal for use in many applications including industrial, process, medical, and are perfectly suited for compressor applications.

General Purpose Filtration

- Civil engineering
- Rock quarrying
- Shot blasting
- Prefiltration for oil removal on dryers
- Industrial

Oil-free Compressed Air Application

- Spray painting
- Air conveying
- Air motors
- Process control
- Blow moldings
- Pre-filter for vacuum pumps

Critical Applications

- Breathing air
- Process air
- Food industry
- Breweries
- Hospital service
- Dryer
- Medical applications
- Film processing

The Numatics Delta Series™ coalescing filters use a borosilicate glass fiber to remove contaminant from air lines. Air flows from the inside to the outside of the element through a converging/diverging pore structure, trapping contaminant particles in the media (not just on the surface) and forcing liquids to form into larger drops and drain to the bottom of the bowl. Numatics filters are used to remove hydrocarbon, oil, liquid water, rust, and more. The coalescing filters are made up of eight main features:

- 1. Inner core**
Prevents element from collapsing in backflow conditions
- 2. Optional internal pleated prefilter**
3.0 micron media protects the fine borosilicate fibers from large particles, extending the life of the coalescing media
- 3. Inner media wrap**
Allows crossflow of gas, which initiates the coalescing process
- 4. Media**
Three coalescing media choices for best performance. Proprietary glass fiber blend combines low differential pressures and high efficiencies with maximum holding capacity (3 micron particulate and adsorbing grade also available)
- 5. Outer media wrap**
Allows crossflow of gas and improves performance
- 6. Metal retainers**
Supports the media both inside and outside during pressure spikes or high differential pressures
- 7. Drain layer**
Large pore fibers allow the large coalesced liquids to drain to the bottom of the bowl
- 8. End caps**
Aluminum end caps provide sturdiness and durability. All elements are clearly engraved with its model number.

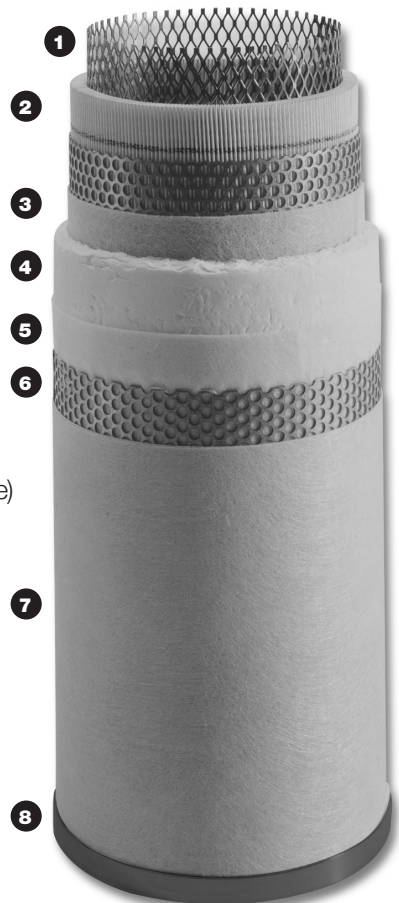

The science of coalescing filtration

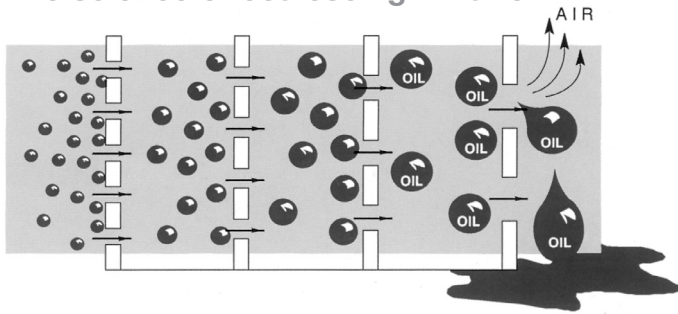

Air flows from the inside to the outside of the element through progressively larger openings in the media. As contamination moves through the element, solid particles are trapped and liquids are formed into large droplets. As the air exits the element, surface tension holds the liquids and allows them to drain to the bottom.

The Numatics 0.01 micron borosilicate glass fiber element, when magnified 228x (left), shows deep, tortuous paths and large air pockets which provide high performance contaminate removal and longer life.

Contamination removal from a typical compressed air line with 0.01 micron Numatics media is shown magnified 40x (right). The contamination contains hydrocarbon (black), oil (opaque drops), and metal fragments (shiny spots).

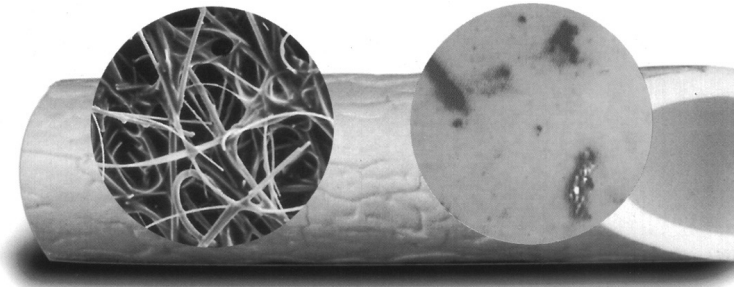

Scanning electron micrograph (at 228x)

Dirty filter magnification (at 40x)

With Numatics elements like the one on the left installed in your system, the contamination on the right won't get to where it can cause damage. Your system lasts longer and costs less.

What you get is not always what you see

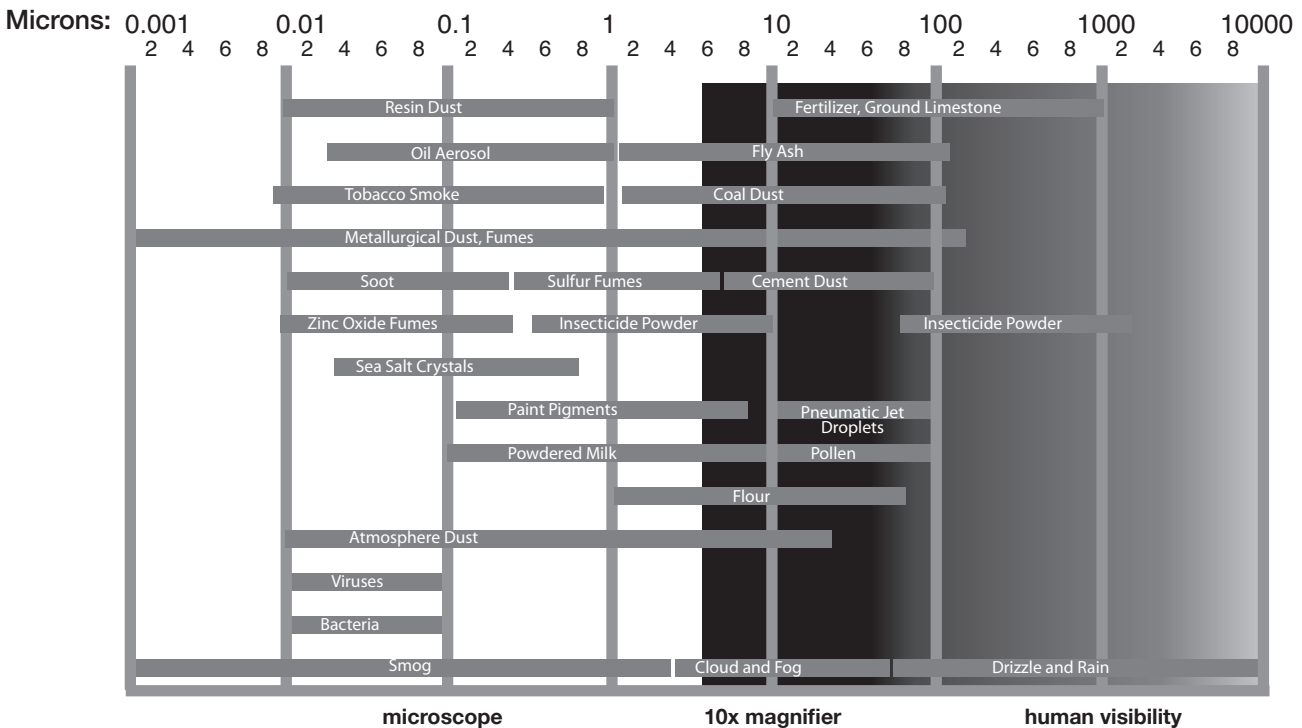



F901X-12 pictured

WATER SEPARATOR

Water Separator - F901X Series
C.R.N. Rated to 200 PSI at 180°F (1/4 to 2" Inclusive)

Application:

The water separator is an ideal solution where water contamination is present. Water can damage pneumatic components, degrade your final product, and cause valves and cylinders to stick.

The water separator utilizes an internal spinner to remove large quantities of contamination by centrifugal action. Water, debris, and rust are spun outward to the inside diameter of the bowl. Gravity then sends the contaminant to the bottom of the bowl for discharge.

Recommended Uses:

- Bulk liquid and solid contamination removal
- Downstream from compressor/aftercoolers
- Protection for coalescing elements from large liquid loading
- Refrigerated compressed air dryers

Materials of Construction:

Head 1/4 - 3: A380.0 Cast Aluminum – Anodized
Bowl 1/4 - 3: A380.0 Cast Aluminum – Anodized
Internal Separator Components: A380.0 Cast Aluminum – Anodized
Seals: Fluorocarbon (FKM)
Standard Manual Drain: Brass

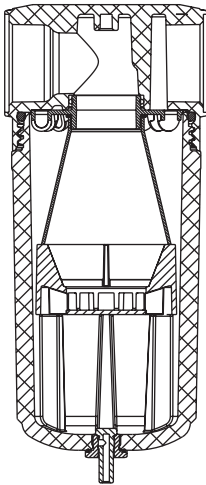

Flow Ratings - Water Separator			
Port Size	SCFM	m ³ /h	Δ P
	Based on 100 PSI (7 bar) inlet		
1/4	30	51	0.75 PSID
1/2	90	153	0.75 PSID
3/4	165	280	0.75 PSID
1	215	365	0.75 PSID
1-1/2	353	600	0.75 PSID
2	706	1200	0.75 PSID

Note: Maximum water removal efficiency occurs at stated flows

How to Order - Water Separators

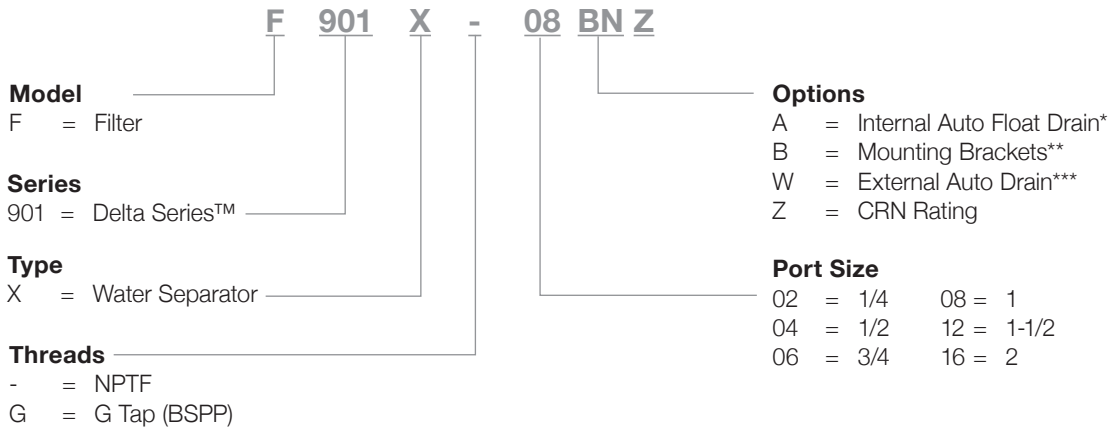

* Applies to 1/4" to 2" Models Only
** Applies to 1/4" to 1-1/2" Models Only
*** Applies to 2" Model Only

Pressure and Temperature Specifications - Water Separators				
Separator Option Type - X	None	A	W	Z
		Float Drain	Ext. Drain	CRN
Port Size	All	1/4 to 2	2	1/4 to 2
Max. Pressure PSI (Bar)	250 (17)	250 (17)	230 (16)	200 (14)
Max. Temperature °F (°C)	200 (95)	150 (66)	120 (50)	180 (82)

Note: Option combinations default to lower pressure and temperature rating.



PARTICULATE GRADE FILTER

ISO CLASS **3** □ □

Particulate Filter – 3.0 Micron - F901G Series
C.R.N. Rated to 200 PSI at 180°F (1/4 to 2” Inclusive)

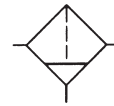

ANSI SYMBOL

Application:

The particulate filter is designed for heavy dirt loading. Large particles such as rust, desiccant dust, and debris will often reduce the life of pneumatic components. Contaminant is generated from desiccant type air dryers, older carbon steel pipes, and from the intake of a compressor.

The particulate 3.0 micron filter element features a pleated design - consisting of cellulose composite media which provides a large amount of surface area and extends the life of the element. When air flows - from the outside of the element to the inside, the particles are trapped in the space between the filter bowl and the element.

Recommended Uses:

- Solid bulk contamination removal
- Afterfilter to a desiccant dryer
- Protection for coalescers in heavy aerosol applications
- 3 micron particle removal in 'dry' systems

Specifications: { Per ISO 12500 at 33.2 ppm Inlet (40 mg/m³) }

- Solid Particle Efficiency: 97.5%
- Maximum Solid Particle Size: 3 µm
- Maximum Solid Concentration: 1.0 mg/m³ / (0.8375 ppm)
- Flow Path: Outside To Inside Of Element

Materials of Construction:

Filter Particulate:

Head 1/4 - 3: A380.0 Cast Aluminum
Bowl 1/4 - 1: A380.0 Cast Aluminum
Bowl 1-1/4 - 3: A356.0-T6 Cast Aluminum
Seals: Fluorocarbon (FKM)
Standard Manual Drain: Brass

Particulate Element:

End Caps: 6061-T6511 Anodized Aluminum
Element: Phenolic Cellulose Pleat
End Cap Bonding Material: Epoxy Resin
Support Cores: Galvanized Carbon Steel

Note: Heads and Bowls – Anodized

Flow Ratings			
Port Size	SCFM	m ³ /h	Δ P
	Based on 100 PSI (7 bar) inlet		
1/4	52	88	1.5 PSID
3/8	67	114	1.5 PSID
1/2	86	146	1.5 PSID
3/4	190	323	1.5 PSID
1	305	518	1.5 PSID
1-1/4	495	841	1.5 PSID
1-1/2	606	1030	1.5 PSID
2	1155	1962	1.5 PSID
2-1/2	1485	2523	1.5 PSID
3	1856	3153	1.5 PSID

Note: Maximum efficiency occurs at stated flows



COARSE GRADE COALESCING FILTER

ISO CLASS 3 4

Coalescing Filter - 1.0 Micron (Coarse Grade) - F901H Series
C.R.N. Rated to 200 PSI at 180°F (1/4 to 2" Inclusive)

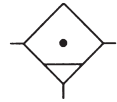

ANSI SYMBOL

Application:

The coarse coalescing filter is utilized when low pressure drop or crude separation is required. The coarse filter element is preferred in low pressure and vacuum application so that the efficiency of the compressor or pump is not sacrificed. Also, the coalescing element will take out crude amounts of large liquid oil and water particles, specifically downstream of a compressor to protect a dryer. The coalescing 1.0 micron coarse grade filter element features a unique vacuum-formed process. It utilizes micro-glass fibers in raw form to create a seamless, depth-loading media. Combined with a rigid fiber-binding epoxy, the filter element has great strength and high efficiency.

Recommended Uses:

- Mainline plant filtration
- Prefilter to refrigerated air dryer
- 1 micron particle removal in 'dry' systems
- Heavy oil concentration removal

Specifications: { Per ISO 12500 at 33.2 ppm Inlet (40 mg/m³) }

- Coalescing Efficiency = 95.0%
- Maximum Solid Particle Size: 1.0 µm
- Maximum Solid Concentration: 2.8 mg/m³ / (2.3 ppm)
- Maximum Oil Concentration: 2.0 mg/m³ / (1.66 ppm)
- Flow Path: Inside to Outside Of Element

Materials of Construction:

Filter Coalescing:

Head 1/4 - 3: A380.0 Cast Aluminum
Bowl 1/4 - 1: A380.0 Cast Aluminum
Bowl 1-1/4 - 3: A356.0-T6 Cast Aluminum
Seals: Fluorocarbon (FKM)
Standard Manual Drain: Brass

Note: Heads and Bowls – Anodized

Coalescing Element:

End Caps: 6061-T6511 Anodized Aluminum
Element: Borosilicate Glass Fibers
End Cap Bonding Material: Epoxy Resin
Support Cores: Galvanized Carbon Steel
Drain Layer: Polyester

Flow Ratings:			
Port Size	SCFM	m ³ /h	Δ P
	Based on 100 PSI (7 bar) inlet		
1/4	49	83	1.5PSID
3/8	59	100	1.5 PSID
1/2	75	127	1.5 PSID
3/4	160	272	1.5 PSID
1	256	435	1.5 PSID
1-1/4	480	816	1.5 PSID
1-1/2	576	979	1.5 PSID
2	1120	1903	1.5 PSID
2-1/2	1440	2447	1.5 PSID
3	1800	3058	1.5 PSID

Note: Maximum efficiency occurs at stated flows



FINE GRADE COALESCING FILTER

ISO CLASS

Coalescing Filter - 0.01 Micron (Fine Grade) - F901D Series
C.R.N. Rated to 200 PSI at 180°F (1/4 to 2" Inclusive)

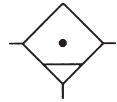

ANSI SYMBOL

Application:

The fine coalescing filter is utilized when clean air is required and longer component life is desired. It is recommended in most point-of-use applications for industrial use. Also, the fine coalescer removes small particles of oil, water, and rust that can create problems in painting and coating processes. The coalescing 0.01 fine grade filter element features a unique vacuum-formed process. It utilizes micro-glass fibers in raw form to create a seamless, depth-loading media. Combined with a rigid fiber-binding epoxy, the filter element has great strength and high efficiency.

Recommended Uses:

- Paint spraying
- Pneumatic tools and instrumentation
- Robotics
- 0.01 micron particle removal in 'dry' systems
- Low oil concentration removal

Specifications: { Per ISO 12500 at 33.2 ppm Inlet (40 mg/m³) }

- Coalescing Efficiency = 99.975%
- Maximum Solid Particle Size: 0.01 µm
- Maximum Solid Concentration: 0.1 mg/m³ / (0.08 ppm)
- Maximum Oil Concentration: 0.01mg/m³ / (0.008 ppm)
- Flow Path: Inside to Outside Of Element

Materials of Construction:

Filter Coalescing:

Head 1/4 - 3: A380.0 Cast Aluminum
Bowl 1/4 - 1: A380.0 Cast Aluminum
Bowl 1-1/4 - 3: A356.0-T6 Cast Aluminum
Seals: Fluorocarbon (FKM)
Standard Manual Drain: Brass

Coalescing Element:

End Caps: 6061-T6511 Anodized Aluminum
Element: Borosilicate Glass Fibers
End Cap Bonding Material: Epoxy Resin
Support Cores: Galvanized Carbon Steel
Drain Layer: Polyester

Note: Heads and Bowls – Anodized

Flow Ratings:			
Port Size	SCFM	m ³ /h	Δ P
	Based on 100 PSI (7 bar) inlet		
1/4	31	53	1.5 PSID
3/8	45	76	1.5 PSID
1/2	51	87	1.5 PSID
3/4	100	170	1.5 PSID
1	130	221	1.5 PSID
1-1/4	253	430	1.5 PSID
1-1/2	309	525	1.5 PSID
2	635	1079	1.5 PSID
2-1/2	828	1407	1.5 PSID
3	947	1609	1.5 PSID

Note: Maximum efficiency occurs at stated flows



ULTRA FINE GRADE COALESCING FILTER

ISO CLASS 1 1

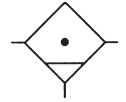

ANSI SYMBOL

Coalescing Filter - 0.01 Micron (Ultra Fine Grade) - F901E Series
C.R.N. Rated to 200 PSI at 180°F (1/4 to 2" Inclusive)

Application:

The ultra fine coalescing filter is ideal where critically clean air is needed and pressure drop is not a concern. It is a polishing filter to clean up any remains of particles or oil that are left over from the compressor room filtration. It is mainly a point-of-use filter that is targeted specifically for critical processes. The coalescing 0.01 ultra fine filter element features a unique vacuum-formed process. It utilizes micro-glass fibers in raw form to create a seamless, depth-loading media. Combined with a rigid fiber-binding epoxy, the filter element has great strength and high efficiency.

Recommended Uses:

- Blow molding plastics
- Semiconductor packaging
- Critical instrumentation
- 0.01 micron particle removal in 'dry' systems
- Low oil concentration removal

Specifications: { Per ISO 12500 at 33.2 ppm Inlet (40 mg/m3) }

- Coalescing Efficiency = 99.99%
- Maximum Solid Particle Size: 0.01 µm
- Maximum Solid Concentration: 0.008 mg/m3 / (0.006 ppm)
- Maximum Oil Concentration: 0.004 mg/m3 / (0.003 ppm)
- Flow Path: Inside to Outside Of Element

Materials of Construction:

Filter Coalescing:

Head 1/4 - 3: A380.0 Cast Aluminum
Bowl 1/4 - 1: A380.0 Cast Aluminum
Bowl 1-1/4 - 3: A356.0-T6 Cast Aluminum
Seals: Fluorocarbon (FKM)
Standard Manual Drain: Brass

Coalescing Element:

End Caps: 6061-T6511 Anodized Aluminum
Element: Borosilicate Glass Fibers
End Cap Bonding Material: Epoxy Resin
Support Cores: Galvanized Carbon Steel
Drain Layer: Polyester

Note: Heads and Bowls – Anodized

Flow Ratings:			
Port Size	SCFM	m³/h	Δ P
	Based on 100 PSI (7 bar) inlet		
1/4	23	39	1.5 PSID
3/8	28	48	1.5 PSID
1/2	35	59	1.5 PSID
3/4	70	119	1.5 PSID
1	110	187	1.5 PSID
1-1/4	180	306	1.5 PSID
1-1/2	216	367	1.5 PSID
2	420	714	1.5 PSID
2-1/2	540	917	1.5 PSID
3	675	1147	1.5 PSID

Note: Maximum efficiency occurs at stated flows



VAPOR ADSORBING GRADE FILTER

ISO CLASS 4 4

Vapor Adsorber Filter - F901F Series
C.R.N. Rated to 200 PSI at 180°F (1/4 to 2" Inclusive)

Application:

The adsorbing filter removes oil and larger hydrocarbon vapor from the compressed air stream. Since it only removes vapor, a coalescing element, specifically the F901D, should be used immediately upstream of the adsorbing filter. Since optimum adsorption occurs at lower temperatures, it is recommended to apply the filter as close to the point-of-use as possible. The fine grade features fine activated charcoal impregnated on polyester media. The activated carbon particles have a high affinity to vapor and are extremely efficient due to the tremendous amount of surface area present. The adsorbing element should be changed every 3 to 6 months depending on the application.

Recommended Uses:

- Breathing air applications
- Food and drug industries having direct product contact with exhaust air
- Odor-free air applications
- Heavier hydrocarbon vapor removal

Specifications:

- Efficiency: 90.0% at Maximum Flow
- Maximum Oil Vapor Concentration: 0.003 ppm based on 0.015 ppm Inlet
- Coalescing Prefilter Recommended
- Flow Path: Outside to Inside Of Element

Materials of Construction:

Filter Adsorbing:

Head 1/4 - 3: A380.0 Cast Aluminum
Bowl 1/4 - 1: A380.0 Cast Aluminum
Bowl 1-1/4 - 3: A356.0-T6 Cast Aluminum
Seals: Fluorocarbon (FKM)
Standard Manual Drain: Brass

Adsorbing Element:

End Caps: 6061-T6511 Anodized Aluminum
Element: Activated Carbon
End Cap Bonding Material: Epoxy Resin
Support Cores: Galvanized Carbon Steel
Outer Drain Layer: Polyester

Note: Heads and Bowls – Anodized

Flow Ratings:			
Size	SCFM	m ³ /h	Δ P
	Based on 100 PSI (7 bar) inlet		
1/4	29	49	1.5 PSID
3/8	63	107	1.5 PSID
1/2	79	134	1.5 PSID
3/4	120	204	1.5 PSID
1	182	309	1.5 PSID
1-1/4	300	510	1.5 PSID
1-1/2	360	612	1.5 PSID
2	700	1189	1.5 PSID
2-1/2	900	1529	1.5 PSID
3	1125	1911	1.5 PSID

Note: Maximum efficiency occurs at stated flows

PREMIUM FILTERS

How to Order: Filters (Particulate, Coalescing & Adsorbing)

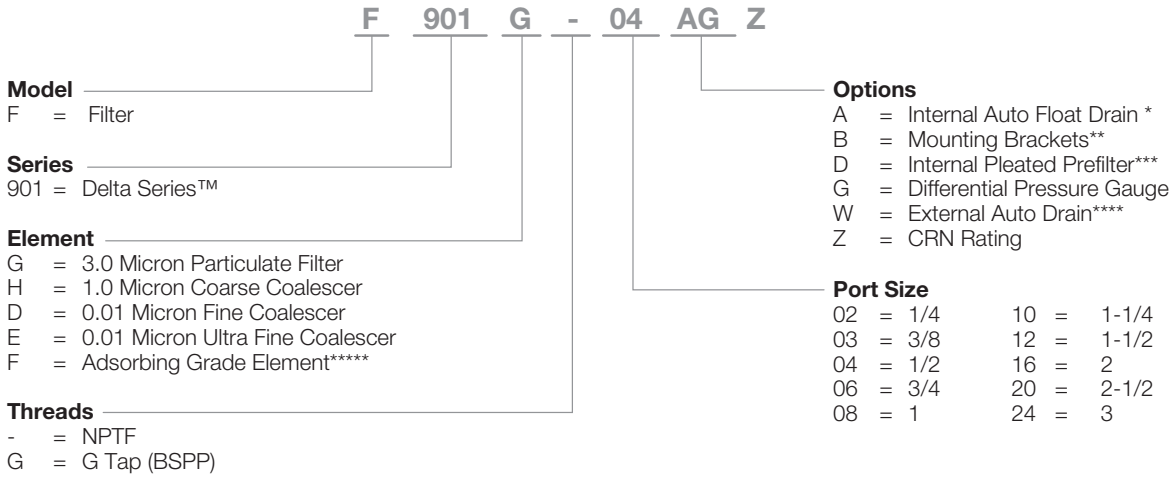

- * Applies to 1/4" to 2" Models Only
- ** Applies to 1/4" to 1-1/2" Models Only
- *** Applies to Elements H, D and E Only
- **** Applies to 2", 2-1/2" and 3" Models Only
- ***** Element Type F Use Only Option B

Optional Internal Pleated Prefilter (See Option D in the "How to Order" for Coalescing Filters.)

Numatics Delta Series™ filters are premium quality filters which include an optional 3.0 micron, internal pleated prefilter. This prefilter provides protection for the fine borosilicate fibers by removing over 97.5% of 3.0 micron and larger particles, extending the life of the filter element.

Pressure and Temperature Specifications – Adsorbing Grade		
Filter Option - Adsorbing Element Grade - F	None	Z
		CRN
Port Size	ALL	1/4 to 2
Max. Pressure PSI (Bar)	250 (17)	200 (14)
Max. Temperature °F (°C)	200 (95)	180 (82)
Min. Temperature °F (°C)	-15F (-26C)	

Note: Option combinations default to lower pressure and temperature rating.
The only optional feature applicable for the adsorbing grade element is the mounting bracket (Option B).

Pressure and Temperature Specifications – Particulate and Coalescing Grades					
Filter Option Elements - G, H, D, E	None	A	G	W	Z
		Float Drain	Delta P Gauge	Ext. Drain	CRN
Port Size	ALL	1/4 to 2	1/4 to 3	2, 2-1/2, 3	1/4 to 2
Max. Pressure PSI (Bar)	250 (17)	250 (17)	250 (17)	230 (16)	200 (14)
Max. Temperature °F (°C)	200 (95)	150 (66)	175 (80)	120 (50)	180 (82)
Min. Temperature °F (°C)*	-15F (-26C)				

Note: Option combinations default to lower pressure and temperature rating.
*Air supply must be dry enough to avoid the formation of ice at temperatures below 32°F (0°C)

FILTER COMBINATIONS

Recommended Filter Combinations - Industry Applications

Flow rates for filter combinations

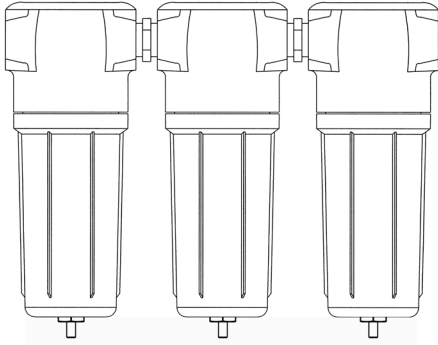

ISO 8573 - The Compressed Air Quality Standard

Class	Solid			Water		Oil Maximum Concentration**	
	Maximum particle size (µm)	Maximum Concentration**		Maximum Pressure Dewpoint			
		ppm	(mg/m3)	degrees F	(degrees C)	ppm	(mg/m3)
1	0.1	0.08	(0.1)	-94	(-70)	0.008	0.01
2	1	0.8	(1)	-40	(-40)	0.08	0.01
3	5	4.2	(5)	-4	(-20)	0.83	1
4	15	6.7	(8)	37	(+3)	4.2	5
5	40	8.3	(10)	45	(+7)	21	25
6	-	-	-	50	(+10)	-	-

* Particle size is based on a filtration ratio 20. The minimum accuracy of the measuring method used is 21% of the limiting value of the class.

** At 14.7 PSI (1 bar) absolute pressure, +70°F (+20°C) and a relative humidity of 60%. It should be noted that at pressures above atmospheric the contaminant concentration is higher.

Applications	Recommended Filter Element Combinations	Port Size				
		1/4	3/8	1/2	3/4	1
		Based on 100 PSI (7 bar) inlet - Δ P 1.5 PSID				
Between aftercooler and dryer	X → H	32 (54)	N/A	65 (108)	132 (220)	196 (327)
Blow molding	G → D → F	20 (33)	32 (54)	38 (64)	71 (119)	100 (167)
Breathing air	G → D → F	" "	" "	" "	" "	" "
Compressed air measuring instruments	G → D	27 (44)	37 (62)	44 (73)	88 (148)	120 (200)
Compressed air motors	G → D	" "	" "	" "	" "	" "
Electronic	G → H → E	19 (32)	24 (39)	30 (50)	61 (101)	96 (160)
Film laboratories	G → D → F	20 (33)	32 (54)	38 (64)	71 (119)	100 (167)
Food packaging	G → D → F	" "	" "	" "	" "	" "
Hospital services	G → D → F	" "	" "	" "	" "	" "
Paint spraying systems	G → D	27 (44)	37 (62)	44 (73)	88 (148)	120 (200)
Paint spraying systems (critical)	G → D → F	20 (33)	32 (54)	38 (64)	71 (119)	100 (167)
Pharmaceutical industry	G → D → F	" "	" "	" "	" "	" "
Pneumatic control systems	G → D	27 (44)	37 (62)	44 (73)	88 (148)	120 (200)
Pneumatic conveying systems	G → D	" "	" "	" "	" "	" "
Pneumatic tools	G → D	" "	" "	" "	" "	" "
Precision analyzers	G → H → F	22 (38)	36 (60)	46 (77)	86 (143)	133 (223)
Process air	H → D → F	19 (32)	31 (52)	37 (62)	69 (116)	98 (163)
Surface treatment	G → H → D	23 (39)	32 (53)	38 (63)	77 (129)	108 (181)

Filter element grades

X = water separator

G = 3.0 micron particulate filter

H = 1.0 micron coarse coalescer

D = 0.01 micron fine coalescer

E = 0.01 micron ultra fine coalescer

F = adsorbing grade filter

FILTER COMBINATIONS

Recommended Filter Combinations - Industry Applications

Flow rates for filter combinations

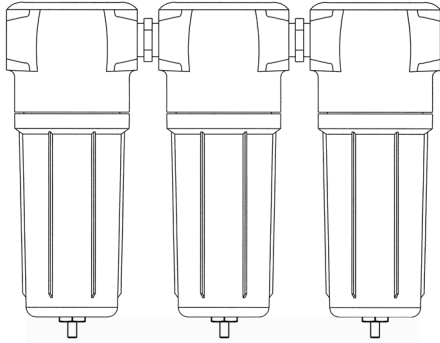

Applications	Recommended Filter Element Combinations	Size				
		1-1/4	1-1/2	2	2-1/2	3
Based on 100 PSI (7 bar) inlet - Δ P 1.5 PSID						
Between aftercooler and dryer	X → H	N/A	377 (630)	745 (1244)	N/A	N/A
Blow molding	G → D → F	180 (301)	219 (365)	436 (727)	564 (941)	675 (1126)
Breathing air	G → D → F	" "	" "	" "	" "	" "
Compressed air measuring instruments	G → D	225 (376)	275 (459)	556 (929)	723 (1207)	844 (1408)
Compressed air motors	G → D	" "	" "	" "	" "	" "
Electronic	G → H → E	160 (266)	192 (320)	372 (621)	479 (799)	598 (999)
Film laboratories	G → D → F	180 (301)	219 (365)	436 (727)	564 (941)	675 (1126)
Food packaging	G → D → F	" "	" "	" "	" "	" "
Hospital services	G → D → F	" "	" "	" "	" "	" "
Paint spraying systems	G → D	225 (376)	275 (459)	556 (929)	723 (1207)	844 (1408)
Paint spraying systems (critical)	G → D → F	180 (301)	219 (365)	436 (727)	564 (941)	675 (1126)
Pharmaceutical industry	G → D → F	" "	" "	" "	" "	" "
Pneumatic control systems	G → D	225 (376)	275 (459)	556 (929)	723 (1207)	844 (1408)
Pneumatic conveying systems	G → D	" "	" "	" "	" "	" "
Pneumatic tools	G → D	" "	" "	" "	" "	" "
Precision analyzers	G → H → F	226 (378)	273 (455)	528 (881)	679 (1133)	848 (1416)
Process air	H → D → F	179 (299)	217 (362)	434 (724)	561 (937)	672 (1122)
Surface treatment	G → H → D	204 (340)	248 (415)	498 (832)	646 (1079)	764 (1275)

Filter element grades

X = water separator

G = 3.0 micron particulate filter

H = 1.0 micron coarse coalescer

D = 0.01 micron fine coalescer

E = 0.01 micron ultra fine coalescer

F = adsorbing grade filter



WATER SEPARATOR & FILTER DIMENSIONS

Dimensions: mm (inches) - Std Manual Drain / Mounting Bracket Dimensions

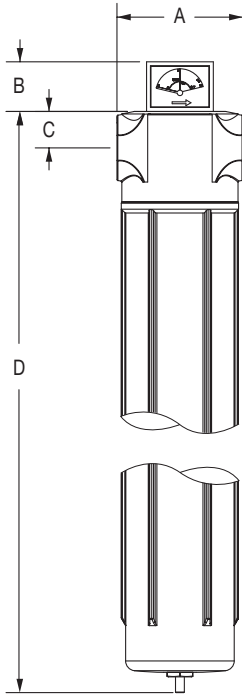

Mounting Bracket Kit

(Includes 2 brackets and required screws)

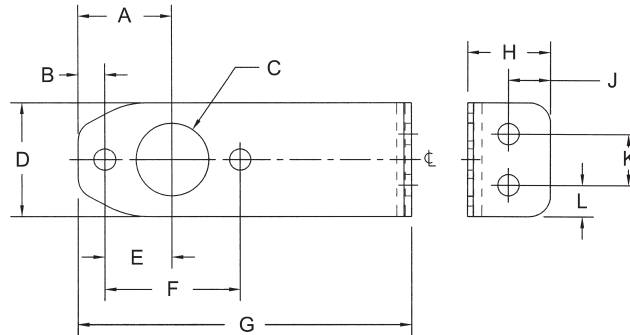

Model	A	B	C	D	E	F	G	H	J	K	L
BRK9001 (1/4-1/2 Models)	1.13 (29)	.32 (8)	Ø.88 (Ø22)	1.38 (35)	.82 (21)	1.63 (41)	4.0 (102)	1.0 (25)	.5 (13)	.62 (16)	.38 (10)
BRK9002 (3/4-1 1/2 Models)	1.5 (38)	.27 (7)	Ø1.94 (Ø42)	2.5 (64)	1.24 (31)	2.47 (63)	5.0 (127)	1.0 (25)	.4 (10)	1.5 (38)	.5 (13)

Water Separator						
Port Size	Weight lbs (kg)	A	B	C	D	E
1/4	2.9 (1.32)	3.7 (95)	N/A	0.79 (20)	9.4 (238)	1.5 (38)
1/2	2.9 (1.32)	3.7 (95)	N/A	0.79 (20)	9.4 (238)	1.5 (38)
3/4	5.4 (2.45)	4.6 (116)	N/A	1.32 (34)	10.8 (274)	1.5 (38)
1	5.4 (2.45)	4.6 (116)	N/A	1.32 (34)	10.8 (274)	1.5 (38)
1-1/2	5.4 (2.45)	4.6 (116)	N/A	1.32 (34)	10.8 (274)	1.5 (38)
2	12.05 (5.47)	6.3 (160)	N/A	1.70 (43)	13.0 (332)	2.0 (51)

*Notes:

"D" dimension includes manual drain.

The "E" dimension refers to the amount of space needed below the bottom of the bowl in order to remove the bowl.

Filter Dimensions						
Port Size	Weight lbs (kg)	A	B	C	D	E
1/4	2.95 (1.34)	3.7 (95)	1.8 (46)	0.79 (20)	9.38 (238)	1.8 (46)
3/8	2.95 (1.34)	3.7 (95)	1.8 (46)	0.79 (20)	9.38 (238)	1.8 (46)
1/2	2.95 (1.34)	3.7 (95)	1.8 (46)	0.79 (20)	9.38 (238)	1.8 (46)
3/4	7.10 (3.22)	4.6 (116)	1.8 (46)	1.32 (34)	14.69 (373)	1.8 (46)
1	7.10 (3.22)	4.6 (116)	1.8 (46)	1.32 (34)	14.69 (373)	1.8 (46)
1-1/4	9.25 (4.20)	4.6 (116)	1.8 (46)	1.32 (34)	21.07 (535)	1.8 (46)
1-1/2	9.25 (4.20)	4.6 (116)	1.8 (46)	1.32 (34)	21.07 (535)	1.8 (46)
2	22.7 (10.30)	6.3 (160)	1.8 (46)	1.69 (43)	26.80 (681)	1.8 (46)
2-1/2	55.0 (25.0)	11.0 (280)	1.8 (46)	2.9 (73)	30.0 (762)	2.2 (56)
3	55.0 (25.0)	11.0 (280)	1.8 (46)	2.9 (73)	30.0 (762)	2.2 (56)

Dimensions: mm (inches) - Option "W" Included

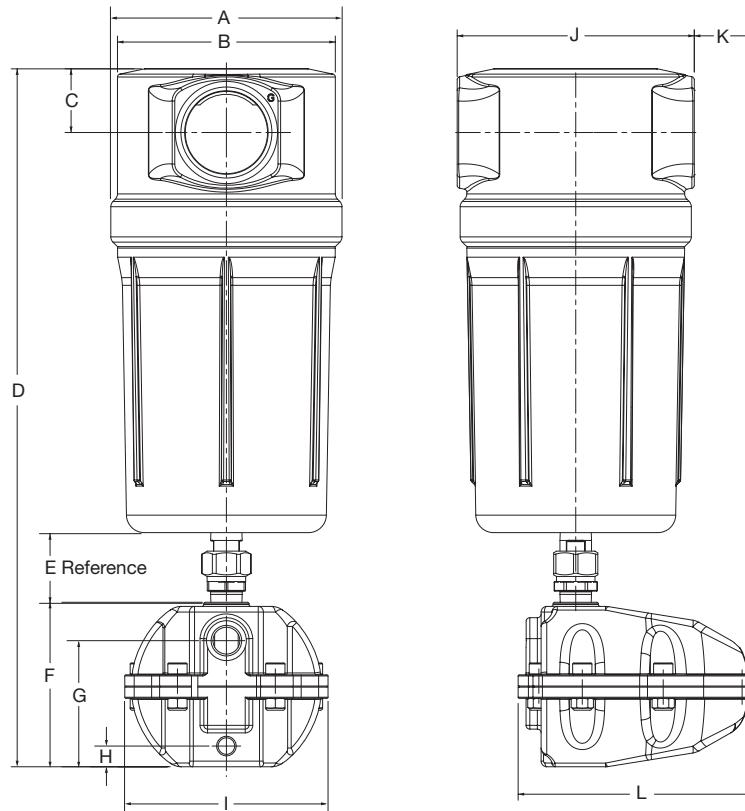

Water Separator													
Port Size	Weight lbs (kg)	A	B	C	D	E	F	G	H	I	J	K	L
2	16.05* (7.3)	6.14 (156)	5.79 (147)	1.69 (43)	18.54 (471)	1.85 (47)	4.37 (111)	3.35 (85)	0.55 (14)	5.39 (137)	6.30 (160)	1.61 (41)	6.30 (160)

* Weight includes W option drain and bushing.

Filter Dimensions													
Port Size	Weight lbs (kg)	A	B	C	D	E	F	G	H	I	J	K	L
2	26.7* (12.14)	6.14 (156)	5.79 (147)	1.69 (43)	26.06 (662)	1.85 (47)	4.37 (111)	3.35 (85)	0.55 (14)	5.39 (137)	6.30 (160)	1.61 (41)	6.30 (160)
2-1/2	59.0* (26.82)	9.05 (230)	8.46 (215)	2.87 (73)	35.53 (905)	1.85 (47)	4.37 (111)	3.35 (85)	0.55 (14)	5.39 (137)	11.02 (280)	-0.75 (-19)	6.30 (160)
3	59.0* (26.82)	9.05 (230)	8.46 (215)	2.87 (73)	35.53 (905)	1.85 (47)	4.37 (111)	3.35 (85)	0.55 (14)	5.39 (137)	11.02 (280)	-0.75 (-19)	6.30 (160)

* Weight includes W option drain and bushing.



Replacement Elements - 901 Series

Replacement Elements Kit	
Includes filter element and seal	
Kit #	Description
1/4, 3/8, & 1/2 Units	
EKF9004G-B	3.0 micron micron particulate
EKF9004H-B	1.0 micron coarse coalescing
EKF9004HD-B	1.0 micron coarse coalescing w/ pleated prefilter
EKF9004D-B	0.01 micron fine coalescing
EKF9004DD-B	0.01 micron fine coalescing w/ pleated prefilter
EKF9004E-B	0.01 micron ultra fine coalescing
EKF9004ED-B	0.01 micron ultra fine coalescing w/ pleated prefilter
EKF9004F-B	adsorbing
Element Only - Weight 0.35 lbs (.16 kg) for all sizes	

3/4 & 1 Units	
EKF9008G-B	3.0 micron micron particulate
EKF9008H-B	1.0 micron coarse coalescing
EKF9008HD-B	1.0 micron coarse coalescing w/ pleated prefilter
EKF9008D-B	0.01 micron fine coalescing
EKF9008DD-B	0.01 micron fine coalescing w/ pleated prefilter
EKF9008E-B	0.01 micron ultra fine coalescing
EKF9008ED-B	0.01 micron ultra fine coalescing w/ pleated prefilter
EKF9008F-B	adsorbing
Element Only - Weight 1.0 lbs (.45 kg) for all sizes	

1 1/4 & 1 1/2 Units	
EKF9012G-B	3.0 micron particulate
EKF9012H-B	1.0 micron coarse coalescing
EKF9012HD-B	1.0 micron coarse coalescing w/ pleated prefilter
EKF9012D-B	0.01 micron fine coalescing
EKF9012DD-B	0.01 micron fine coalescing w/ pleated prefilter
EKF9012E-B	0.01 micron ultra fine coalescing
EKF9012ED-B	0.01 micron ultra fine coalescing w/ pleated prefilter
EKF9012F-B	adsorbing
Element Only - Weight 1.85 lbs (.84 kg) for all sizes	

2 Units	
EKF9016G-B	3.0 micron micron particulate
EKF9016H-B	1.0 micron coarse coalescing
EKF9016HD-B	1.0 micron coarse coalescing w/ pleated prefilter
EKF9016D-B	0.01 micron fine coalescing
EKF9016DD-B	0.01 micron fine coalescing w/ pleated prefilter
EKF9016E-B	0.01 micron ultra fine coalescing
EKF9016ED-B	0.01 micron ultra fine coalescing w/ pleated prefilter
EKF9016F-B	adsorbing
Element Only - Weight 3.6 lbs (1.64 kg) for all sizes	

2 1/2 & 3 Units	
EKF9024G-B	3.0 micron micron particulate
EKF9024H-B	1.0 micron coarse coalescing
EKF9024HD-B	1.0 micron coarse coalescing w/ pleated prefilter
EKF9024D-B	0.01 micron fine coalescing
EKF9024DD-B	0.01 micron fine coalescing w/ pleated prefilter
EKF9024E-B	0.01 micron ultra fine coalescing
EKF9024ED-B	0.01 micron ultra fine coalescing w/ pleated prefilter
EKF9024F-B	adsorbing
Element Only - Weight 6.35 lbs (2.88 kg) for all sizes	

Bowl Replacement	
Includes Bowl Only	
Bowl #	Description
BKF9001-B	for 1/4, 3/8, & 1/2 units
BKF9002-B	for 3/4 & 1 units
BKF9004-B	for 1-1/4 & 1-1/2 units
BKF9005-B	for 2 unit
BKF9006-B	for 2-1/2 & 3 units

Separator Bowl	
Includes Bowl Only	
Bowl #	Description
BKF9001-B	for 1/4 & 1/2 units
BKF9004S-B	for 3/4, 1, 1-1/2
BKF9005S-B	for 2 units

Filter & Separator Head Replacement Seals	
Includes O-ring Only	
FPHS9001-04	for 1/4, 3/8, & 1/2 units
FPHS9001-12	for 3/4, 1, 1-1/4, & 1-1/2 units
FPHS9001-16	for 2 units
FPHS9001-20	for 2-1/2 & 3 units



Global Contacts

Australia	(61) 2-9-451-7077	France	(33) 2-37-24-42-24	Netherlands	(31) 33-277-7911
Brazil	(55) 11-4208-1700	Germany	(49) 7237-9960	Singapore	(65) 6556-1100
Canada	(1) 519-758-2700	India	(91) 44-39197300	South Korea	(82) 2-3483-1570
China	(86) 21-3395-0000	Italy	(39) 02-356931	Spain	(34) 942-87-6100
Czech Republic	(420) 235-090-061	Japan	(81) 798-65-6361	United Kingdom	(44) 1695-713600
Dubai - UAE	(971) 4-811-8200	Mexico	(52) 55-5809-5640		