

PRECISION REGULATOR

numatics

G 1/4 to G 1/2

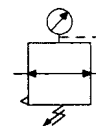

Series
R80-R82
R88

FEATURE

- High precision and multi-stage pressure regulators
- Standard version R80, high relief version R82 and high flow version R88

GENERAL / OPERATING PRINCIPLE

For R80-R82 series, the highest degree of regulation are achievable by reacting to downstream pressure fluctuations as small as 0,7 mbar. Action occurs as downstream pressure is piloted to the control chamber to act on a finely tuned stainless steel volume capsule.

A continuous bleed adjusts the pilot diaphragm causing appropriate movement of the valve.

The R88 Series pressure control regulator is designed for high flow and accurate pressure control utilizing a rolling diaphragm to insure a constant output pressure

SPECIFICATIONS

	R80 - R82	R88
Flow rate (ANR)	460 l/min	1800 l/min (courbes p 2)
Relief capacity	R80 = 62 l/min ANR R82 = 305 l/min ANR	120 l/min ANR
Sensitivity	3 mbar	0,6 mbar
Pilot bleed rate	2,5 l/min	0,55 à 6,5 l/min
Maximum supply pressure	10 bar	17 bar
Filtered air	25 µm	25 µm
Max.oil concentration in air	1 mg/cm ³	

CONSTRUCTION

Body	Die cast zinc
Diaphragms	NBR
Knob	Phanolic plastic

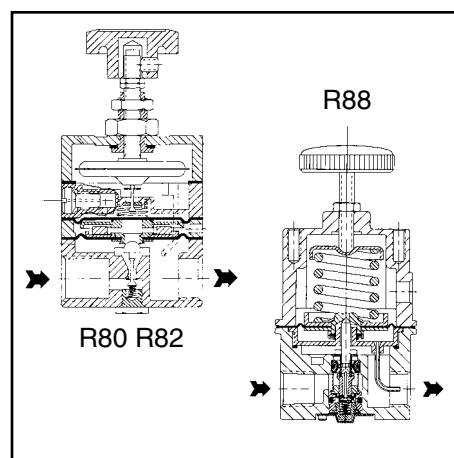

CHOICE OF EQUIPMENT

R80 0G 02 F G

Precision regulator	type
standard	R80
High relief precision regulator	R82

Options	
-	Without option
G	With gauge
T	Tamperproof

Port size	
G1/4	02
G3/8	03

Pressure range	
D	0,1 à 2,8 bar
E	0,1 à 4 bar
F	0,1 à 8 bar

APPLICATIONS

- Air gauging, Gas mixing, Web tensioning, Roll loading, Air hoists

R88 0G 02 F G

Precision regulator	type
High flow precision regulator	R88

Options	
-	Without option
G	With gauge
M	Mounting brackets

Port size	
G1/4	02
G3/8	03
G1/2	04

Pressure range	
A	0 à 0,1 bar
B	0 à 1 bar
C	0 à 2 bar
E	0,05 à 4 bar
F	0,1 à 10 bar

APPLICATIONS

- Test equipment, Roll loading, Web tensioning, Actuators, Gas mixing, Test panels, Clutch and brake controls

Order exemple: **R800G02F**

This is a R80 Series Precision Regulator with high relief. Port size is G 1/4. It has a pressure range from 8 bar

ACCESSORIES

Gauge with Center Back Mount

G Option

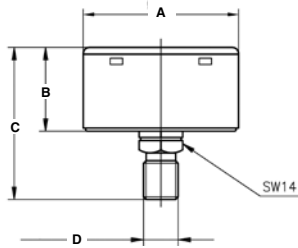

Technical Data and Dimensions (mm)

Type	Option	Code	Pressure Range [psi/bar]	A Ø	B	C	D
standard	G	RB060	0 à 4	50,0	26	44	R 1/4
		RB160	0 à 10	50,0	26	44	R 1/4

Mounting Brackets

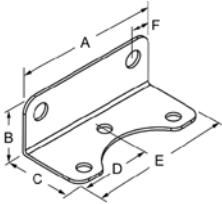

Dimensions [mm]

Code	Series	A	B	C	D	E	F
PK88	R88	76,0	29,0	35,0	38,0	76,0	10,0
PK80	R80 & R82	—	—	—	—	—	—

DIMENSIONS in inch (mm), WEIGHT (g)

Regulators R80 et R82

Tamperproof Model

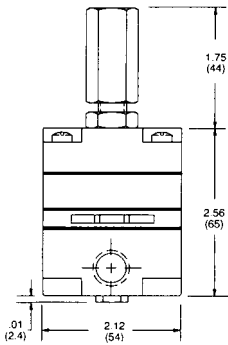

Weight
R80 - R82 : 64 g
R88 : 74 g

Knop Model

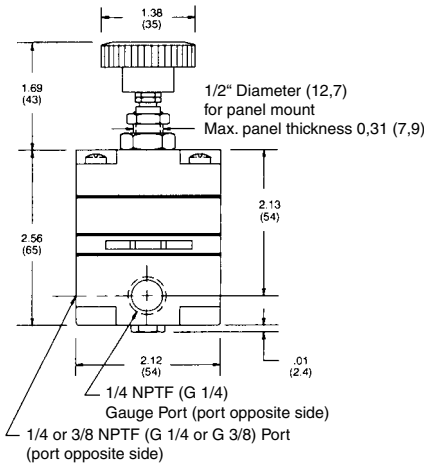

Regulators R88

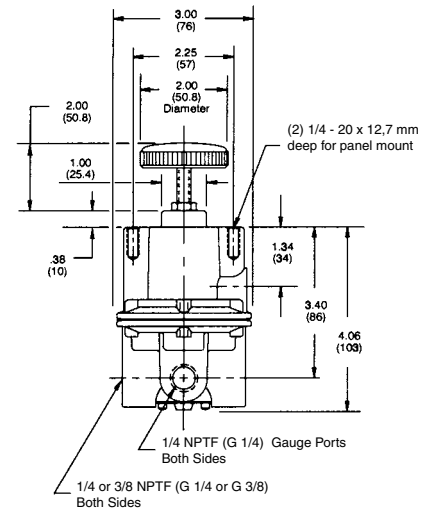

STANDARD HIGH FLOW PRECISION REGULATOR Series R88

