

**PRECISION VERNIER CALIPER**  
Series 160

Ref. No. 160-04-1983-JAN

**160 シリーズ**  
**C, CM 形ノギス**

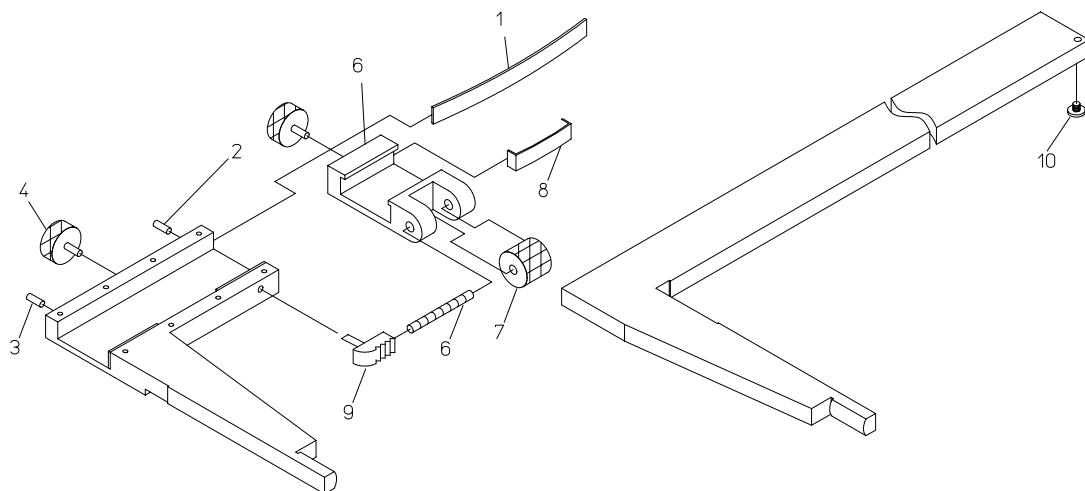

書類NO. 160-04

KEY NO.	品名	PART NAME	販売区分 CATEGORY	CODE NO. コードNO.						備考 COMMENTS
				160-173 C20	160-172 C8"	160-175 CM20P	160-183 C30	160-181 C12"P	160-185 CM30P	
1	イタハネ	GIB, SLIDER			114532			140906		
2	セットネジ	SCREW, GIB SETTING			101562			135426		
3	オンネジ	SCREW, GIB PRESSING			101820			135427		
4	クランプネジ	CLAMP, SLIDER			135398			142150		
5	オクリネジ	SCREW, FINE ADJUSTING			-	131419		-	114033	
6	オクリハコ	CARRIER				131424		-	140006	
7	オクリナット	NUT, FINE ADJUSTING				114036		-	114036	
8	オクリハコイタハネ	GIB, CARRIER				127499		-	127499	
9	ユビカサ	KNOB, CARRIER			900298	905124		900298	905124	
10	ストップネジ	SCREW, SLIDER STOP					140424			

Ref. No. 160-04-1983-JAN